

Daily pre-use checks:-

- | | | | |
|----|--|--------------------------|-------|
| 1: | Height adjustment levers tight | <input type="checkbox"/> | |
| 2: | Castor brakes all function | <input type="checkbox"/> | |
| 3: | Seat free from cuts, damage or loose stitches | <input type="checkbox"/> | |
| 4: | Seat correctly fitted - see illustration below | <input type="checkbox"/> | |
| 5: | Seat hook fits securely to the arm of the Cricket | <input type="checkbox"/> | |
| 6: | Backrest pads secure and undamaged | <input type="checkbox"/> | |
| 7: | Knee pad secure and fitted in the correct position | <input type="checkbox"/> | |
| 8: | Footplate covering secure and clean | <input type="checkbox"/> | |

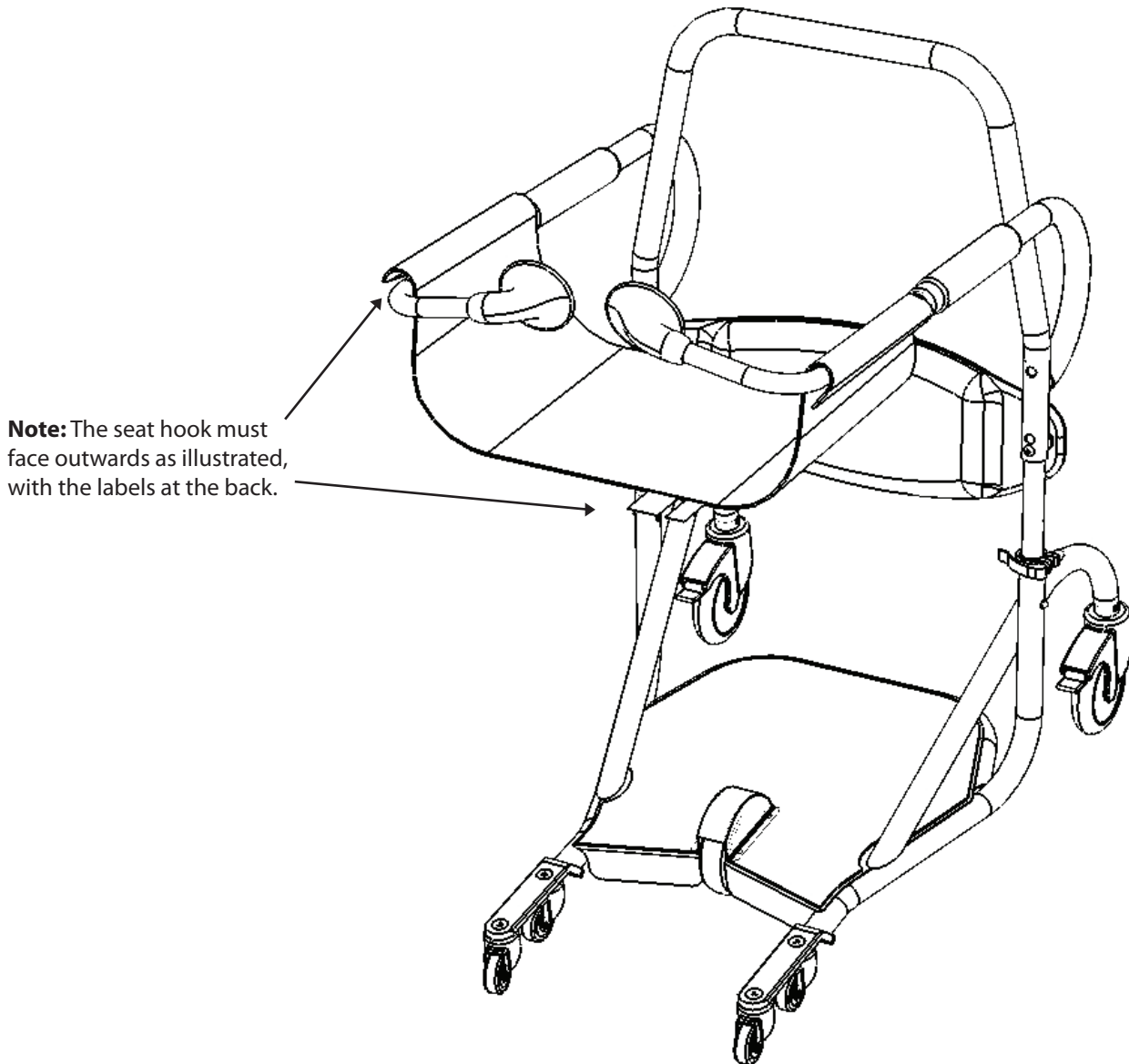

Safety warning

Only use as instructed. Ensure that users are familiar with these instructions with the operation before use.

- * Do not use if any part is damaged
- * Do not use the Cricket to transfer outdoors or in vehicles
- * Only use on flat level surfaces
- * Ensure that both castor brakes are applied before transferring a patient to or from the Cricket
- * Do not raise the height of the Cricket higher than allowed by the top spring button position
- * Do not attempt to adjust the height of the Cricket while in use with a patient

